

## CONTENTS

1. Features and specifications . . . . .	2
1.1. Features . . . . .	2
1.2. Specifications . . . . .	2
2. Assembly . . . . .	3
2.1. Assembly of support . . . . .	3
2.2. Assembly of microscope . . . . .	3
2.3. Assembly of operation handle . . . . .	4
2.4. Assembly of fiber optics . . . . .	4
2.5. Assembly of bulb socket . . . . .	4
2.6. The way to accemble the instrument on the wall . . . . .	4
3. Application of Instrument . . . . .	5
4. Maintenance . . . . .	6
4.1. Replacing the bulb . . . . .	6
4.2. Maintenance . . . . .	6
5. Supplyment and Tools . . . . .	7

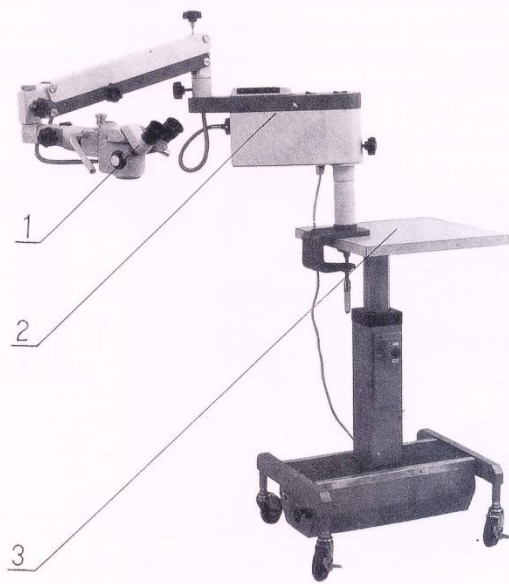

Fig.1

- [1] Microscope
- [2] Support
- [3] Instrument table

1. Features and Specifications

1.1 Features

The YZ20P Operation Microscope is for popular use. The characteristic is that the small and portable machine body makes it have high mobility, and there are three magnifications for choosing. The coaxial fiber optics illumination system is assembled. There is a spring balance system inside the arm so that the operation microscope can move upwards and downwards at one's willing and the doctor can do the fine focus adjusting. The features are sure to meet the requirements of general micro-operations. Through different components and changing working conditions, this machine is suitable for the micro-operations and fine examinations of ophthalmic, otorhinolaryngic, surgery and gynecologic, etc.

1.2 Specifications

(1) Main specifications of microscope

Two focal distances of front objectives:  $f=200$ ,  $f=300$

Magnification of objectives-----12.5x

Adjustable range of diopter-----  $\pm 6$  Diopter

Magnifications and diameter of visual field :

Focal Distance of Front Objectives	Total Magnification	Diameter of Visual Field ( mm )
$f=200$	6x	38
	10x	23
	16x	14
$f=300$	4.2x	55
	6.7x	34
	11x	22

Adjustable range of microscope focal distance: 50mm~ 70mm

Practical working distance: (distance between the operation surface to front surface of objective): 190mm, 290mm

(2) Controlling range of microscope

Maximum stretch radius of microscope arm: 860mm

Working height of microscope : from floor to front surface of objective: 800-1400mm

Vertical movement range of instrument table :200mm

Adjustable range of small arm 400mm

Adjustable range of fine focus adjustment 200mm

Small arm can rotate horizontally at an angle of 300°

Large arm can rotate horizontally at an angle of 360°

(3) Illumination

Internal coaxial illumination is fiber optics and has two steps, one is high (5000lx) and another is low (3000lx). Blue and green filters are available

Halogen bulbs for cold light source: 12V100W bulb

Voltage of power supply : AC110V $\pm$ 10%,60Hz/AC220V $\pm$ 10%,50Hz

## 2. Assembly

### 2.1 Assembly of Support

- (1) No allowance of rotating the small arm (Fig.3-2) before assembly, so as not to twist and damage the fiber optics. No allowance of loosening the screw (Fig.3-1) for avoiding the small arm to spring up to hurt someone.
- (2) Assemble the support at one shrinking side of the table. Press the steps of gripping holder close to the side of the table before gripping. Switch on the leadscrew to press the spacer on the metal plate under the table. Lift up the lever at the angle of  $90^\circ$  for gripping.
- (3) Loosen the fixation screw (Fig.4-4). Turn the small arm (Fig.3-2) at an angle. Fasten it with a hexagon lever (Fig.3-3) so that the small arm will not rotate at full angle of  $360^\circ$  (refer to Fig.3).

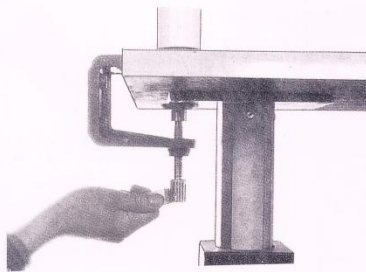

Fig.2

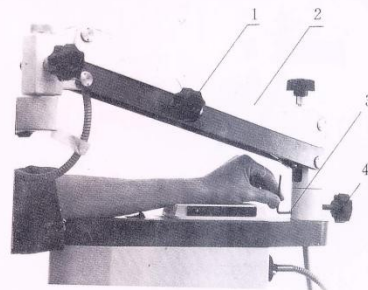

Fig.3

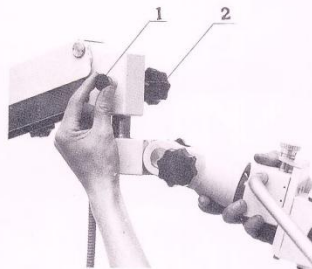

Fig.4

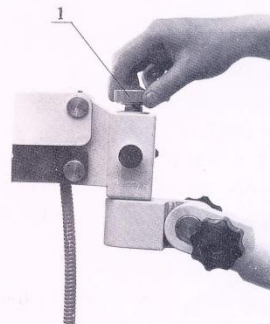

Fig.5

### 2.2 Assembly of microscope

- (1) Check the fixation screw (Fig.4-2) so that the terminal of the screw is sure to be inside of the hole wall.

- (2) Switch off the suspension screw (Fig.5-1). Pull out the locking pin (Fig.4-1) with one hand, and hold the microscope connection (refer to Fig.4) with another hand. Insert the axis into the hole of arm from the bottom up. Loosen the locking pin, it will spring back to fit in the groove. Finally, fasten the suspension screw (refer to Fig.5)

#### 2.3 Assembly of operation handle

- (1) Insert the handle (Fig.6) into the two side holes in front of the microscope. The proper handle position should be down to an angle of  $40^\circ$ . If it is up to an angle of  $40^\circ$ , exchange two handles at the both sides of the microscope

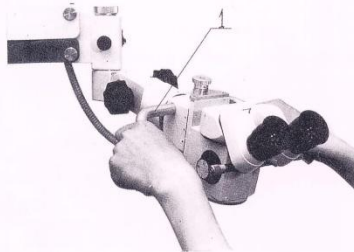

Fig.6

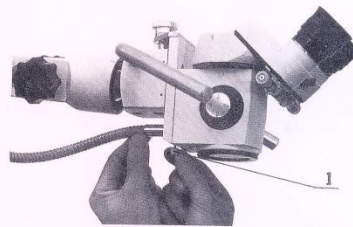

Fig.7

#### 2.4 Assembly of fiber optics

- (1) Screw off the fiber optics protecting cover  
 (2) Insert the fiber optics into the hole on the lower part of microscope to a great degree. Then tighten the screw (Fig.7-1). If the fiber optics cannot be inserted, check whether the screw tip has been out of the hole wall. After the screw is out, the fiber optics can be inserted (refer to Fig.7). Thus the whole assembly procedure is over.

#### 2.5 Assembly of bulb socket

- (1) Pull out the bulb socket (Fig.8-1) from the package box and plug it into the light box (Fig.8-2).

#### 2.6 The way to assemble the instrument on the wall

(refer to Fig.10)

- (1) Assembly with M6 inflation screw according to size

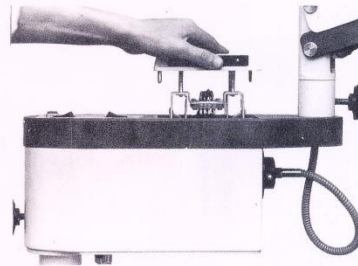

Fig.8



requirement of Fig.10. Height is fixed according to the certain operation table.

### 3. Application of Instrument

- (1) Choose working distance. There are two objectives with f200 and f300. Choose one of them according to requirement of operation. (Usually the microscope is assembled with f200 objective before leaving the factory).
- (2) Take off the operation handle and sterilization cover, and have them sterilized before using. Assemble it while using.
- (3) Release the brake with one foot (refer to Fig.11). Move the instrument to a proper position. Stamp down the brake wing so that the machine isn't able to move. Then insert the power plug of microscope into the 220V output socket on the lower part of the base. Connect 220V input with power source.
- (4) Make the small arm be in a horizontal position. Adjust the table height. Be sure the objective is about 200mm from the floor.
- (5) Check the mark on left side of microscope before using. Turn the focus adjustment knob (Fig.12-2). Be sure the green dot is between two red dots, so that there is an adequate space for fine adjustment. The eye cover should be folded down while watching with glasses, so that the glasses frame will not touch the glass frame and the microscope will not quiver. Then adjust the diopter to the mark "o".
- (6) Release the knob (Fig.3). Hold the handle to move the microscope upward or downward to adjust the focus till the image is clear to a great degree. Fasten the knob (Fig.3-1). Adjust the fine adjustment knob (Fig.12-2). Watch with one eye to make the image clear. Then adjust another eyepiece to be sure that the image getting with another eye is also clear. Then watch the image with two eyes simultaneously. Adjust the pupil distance knob (Fig.12-4) to be sure that the image both eyes get meet together and stereoscopic feeling can be got.
- (7) While doing otorhinolaryngic operations, release the knob (Fig.12-1). Operate the handle (Fig.12-3) to

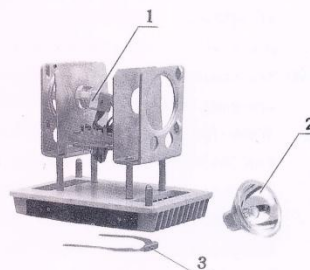

Fig.9

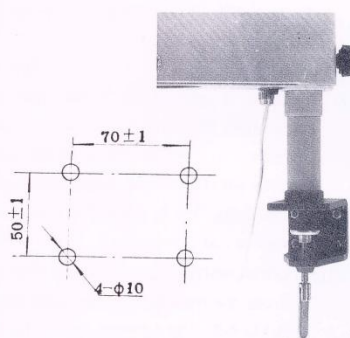

Fig.10

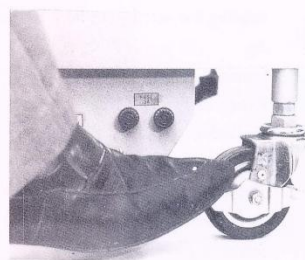

Fig.11

make the microscope forward or backward ,leftward of rightward. When a best angle is got, the knob (Fig.12-1) should be refastened.

- (8) Recompositiond is needed while doing gynecologic operation (refer to Fig.13)

While recompositing, release the screw (Fig.7-1). Pull out the fiber optics. Take out the fixation screw (Fig.4-2). Screw off the suspension screw (Fig.5-1), Pull out the locking pin (Fig.4-1). Take off the microscope carefully. Insert the microscope axis into the hole from the bottom up. Fasted the suspension screw (Fig.5-1). Release the knob (Fig.13-1). Push the microscope upward to be sure the microscope is in a horizontal condition . Fasted the knob (Fig. 13-1). Finally insert the fiber optics.

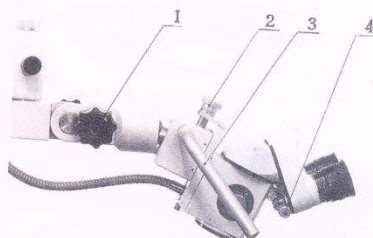

Fig.12

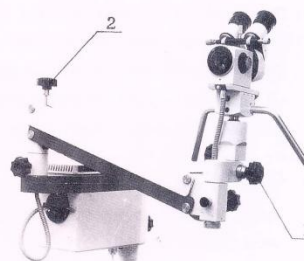

Fig.13

#### 4. Maintenance

##### 4.1 Replacing the bulb

- (1) There is a spare bulb in the light house of the instrument. If the bulb is burned off during the operation, turn off the power switch and pull out the bulb socket (Fig.8-1). Rotate the bulb socket to 180° degree and insert it again. Turn on the switch. The operation can be continued.

- (2) A bulb should be changed in time after an operation for being ready for next operation.

Pull out the socket from the light base (Fig.9-1). Draw out the spring opressor (Fig.9-3). The bulb(Fig.9-2) can be taken out (refer to Fig.9). Then fix the new bulb in a reverse way. (Cold mirror halogen bulb 12V100W )

- ★ NOTICE: The ballance setting of the instrument has been checked and adjusted strickly before leaving the factory, so no allowance of turning the knob at your willing during operation. (Fig.13-2)

##### 4.2 Maintenance

- (1) Every insrtument has been fully checked before distribution. It should not be disassembled by unskilled or unqualified technicians. Otherwise the instrument maybe damaged and the quality should not quality should not be assured.
- (2) The instrument should not be placed in a dusty, moist or corrosive environment.
- (3) Every lens should not be disassembled . If there are dusts stained on the lens, blow them with a bellows grobe or brush them with a dust pen. Greasy or water stains can be cleaned off with a drop of liquid solvent (1:1 mixfure of alcohol and ether),then blow it dry . Be careful to prevent the solvent from infiltrating the edges of lens.
- (4) The needless accessories should be put in a closed box packed with moisture--absorber.
- (5) The stretch arm should be kept in a minimum distance from the microscope. While the instrument

is moving, the center of gravity of instrument should be in the center of the base. Fasten every fixation knobs. Thus the instrument maybe not damaged or fall while moving.

#### 5. Supplyment and Tools

Objective of f300	x1
Sterile covers for fixation screw	x5
Sterile covers for micro - adjustment knob	x1
Sterile covers for magnification adjustment	x2
Sterile covers for pupillary distance adjustment	x2
Cold mirror halogen bulbs 12V 100W	x2
T type AC250V 1.25A or T type Ac 125V 2.5A fuse tube	x2
4mm hexagon lever	x1
P54M lamp base	x2

Thank you for purchasing the YZ20P Microscope. To get the best use from the instrument. Please carefully read the instructions, and place it in a convenient location for future refence. The "★" part have relationships with safety. Please pay attention.

If the instrument you purchase has some difference with that the picture of this instructions, It never mind to use it.